

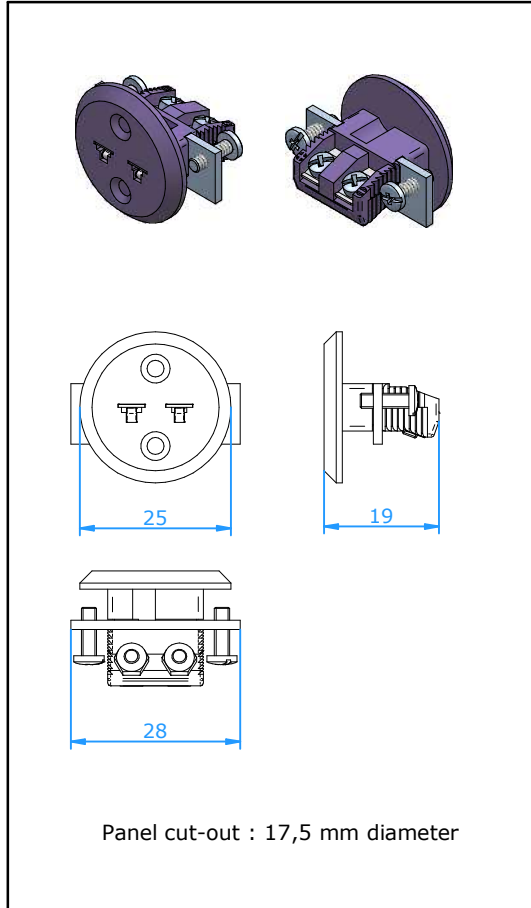

Panels

Panel Miniature Insert Round Bracket Mount



Application

Panel insert for thermocouple and RTD circuits.
Mounting by means of a stainless steel bracket with two screws behind the panel. Ideal panelinsert for instrument cases.

Construction

- Glass filled thermoplastic body with original thermocouple material pins and springloaded inserts.
- Polarized pins ensure proper connection.
- Easy wire connection through sandwich construction.
- Molded barriers prevent short circuit.
- Rugged one body design.
- Polarity indication on body
- Stainless steel bracket and screws for rear panel mounting

Wire size

- Accepts wires up to 1,6 mm.

Temperature rating

- 220 °C Max.

Color Code

- Available in all color code standards. Incl. NFE, BS, JIS, etc.

Accessories

- Panel Punch for 11/16" – 17,5 mm, partnr. 20.366

Ordering Code : **PMIRB-xx**

For last two digits 'xx' see table below

Calibration Code	E	J	K	N	T	U	R/S	C	B
Compensation material for							Pt13Rh/	W5Re/	Pt6Rh/
Material Positive							Pt	W26Re	Pt30Rh
Material Negative	NiCr	Fe	NiCr	NiCrSi	Cu	Cu	Cu	CPX	Cu
	CuNi	CuNi	NiAl	NiSi	CuNi	Cu	Alloy #11	CNX	Cu
IEC Color Code									
Color Body	Violet	Black	Green	Pink	Brown	White	Orange	Red	Grey
Code	EI	JI	KI	NI	TI	UI	RI	C	BI
ANSI Color Code									
Color Body	Violet	Black	Yellow	Orange	Blue	White	Green	Red	Grey
Code	EI	JI	KA	NA	TA	UI	RA	C	BI
DIN Color Code									
Color Body		Blue	Green		Brown		White		Grey
Code		JD	KI		TI		RD		BI