

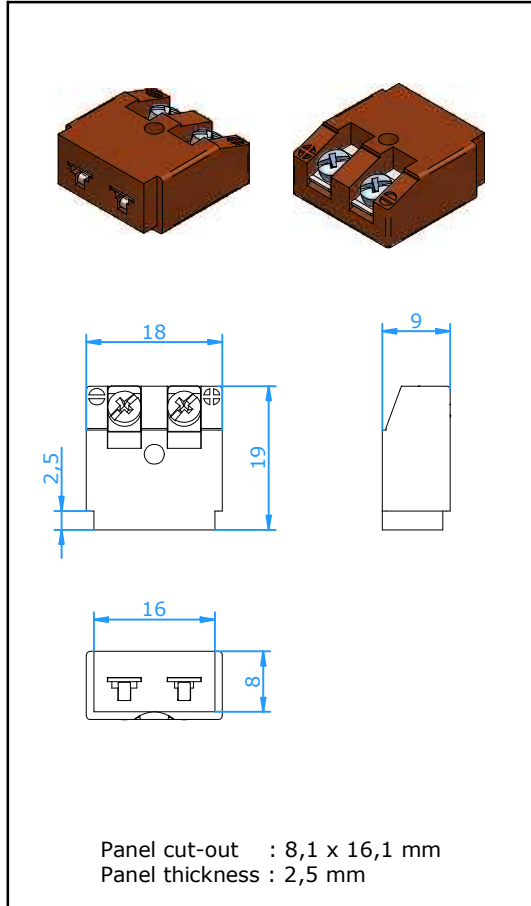

Panels

Panel Miniature Insert High Temperature



Application

Panel insert for thermocouple and RTD circuits.

Specially designed to be used together with **Hamitherm** miniature panel set.

Construction

- Thermoset body with original thermocouple material pins and springloaded inserts.
- Polarized pins.
- Molded barriers prevent short circuit.
- Rugged one body design
- Polarity indication next to connection screws.

Wire size

- Accepts wires up to 0,6 mm.

Temperature rating

- 350 °C Max.

Color Code

- Body color brown. Calibration indication printed on body

Accessories

- Should be used with **Hamitherm** panel sets. Please see separate specification sheet.

Ordering Code : **PMIH-x** 'x' is Calibration Code (see tabel below)

Calibration Code Compensation material for	E	J	K	N	T	U	R/S Pt13Rh/ Pt	C W5Re/ W26Re	B Pt6Rh/ Pt30Rh
Material Positive	NiCr	Fe	NiCr	NiCrSi	Cu	Cu ¹⁾	Cu	CPX	Cu ¹⁾
Material Negative	CuNi	CuNi	NiAl	NiSi	CuNi	Cu ¹⁾	Alloy #11	CNX	Cu ¹⁾